



# RDAc I/O

## MODEL: P01001A1

The Micro RDAc I/O fits into the bottom end of the RDAc range, with a smaller number of inputs and outputs.

Serial Interface to the device is via RS485 or RS232 using a Modbus RTU protocol.

## FEATURES

- ◆ 8 Bit Cpu
- ◆ Small Form Factor DIN rail mountable
- ◆ 8 Digital inputs or  
8 Digital outputs or  
8 Analogue inputs or  
any combination of the above  
up to 8 channels
- ◆ Lightning protected RS485 interface
- ◆ Analogue Inputs 0 – 5V  
(Accuracy < 0.5 % of span)
- ◆ RS485 connected via screw terminals
- ◆ Jumper selectable RS485  
Line termination
- ◆ Analog Non Isolated single ended (0-5V)
- ◆ Digital Input Non Isolated 5-24V  
(Source input 1mA)
- ◆ Digital Output Non Isolated  
Non protected open collector output  
(100mA sink)
- ◆ Counter or pulse input speed (50Hz max)



## SPECIFICATIONS

8 Supply	- 12 to 30VDC
8 Power	- 2,5 Watt
8 RS232	- RJ45, 8 Pin
8 RS485	- Convenient Screw terminal
8 Baud-rates	- 1200 to 19200
8 Temp	- 0°C to 50°C
8 Storage	- 10°C to 70°C

## SUPPLIED BY:

Cybernetic Software Development c.c.

✉ 60424 Vaalpark 1948 R.S.A. Unit E Riemland Office Park Vaalpark Sasolburg

☎ International - +27 16 9712591/2  
Local - (016) 9712591/2

FAX International - +27 16 9712573  
Local - (016) 9712573

EMAIL csowf@mweb.co.za

## Field signal overview:

There are quite a few questions that should be asked, to successfully connect process field sensor signals to a control and measurement piece of equipment:

- What type of signal is the sensor providing
  1. Digital input
  2. Digital output
  3. Pulse input signal
  4. Analog input
  5. Analog output
- Drive capability of the input signal
- Does the input signal sink or source
- Speed at which the input signal changes
- Resolution required if it is an analog signal
- Counting range if the input signal is a pulse type
- Is the signal protocol related
- Is galvanic isolation required

To answer all these question in detail can be a case study on its own. All I want to point out is that there are quite a few determine factors in choosing the correct type of I/O. In the pass you would have a different type of I/O module for every one of the type of field signals you are intending to measure.

To over come the above problem the so-called universal I/O appeared. To design such a product to provide in the total I/O market is not only very complex, but also very expensive. To compromise we looked at which field signals are required most of the time and what type of levels can be accommodated cost effectively.

With the above information our universal input, output equipment tries to be as versatile as possible and are still very cost effective.

*(We do not mean universal in the sense of any mode and any signal type.)*

The uRDAC and RDAC-II I/O product is versatile in the sense that it provides the user with a single product element to:

- Measure digital input signals
- Measure analog input signals
- Measure digital pulse signals (Counters)
- Output digital signals

It is still however necessary for the user to make sure that the interfacing is done correctly between the sensor and the equipment. Although this was limited to the minimum external components (most of the time only a resistor), there are still some factors to take in consideration.

**uRDac – (ecLOG uIO) input arrangement:**

All channels use the same input technology:

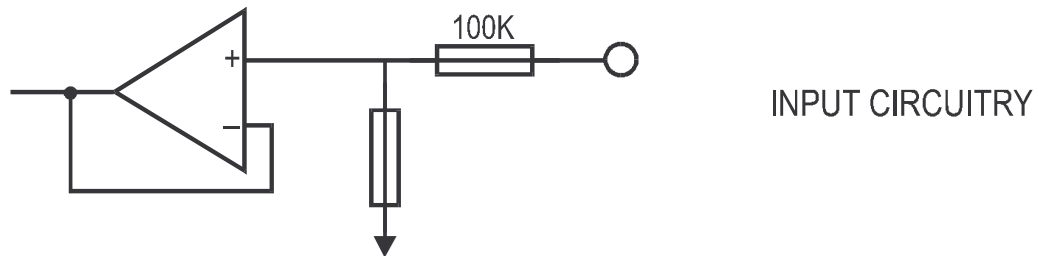

For Analog input signals other than 0 – 5V input conditioning must be done.

**FOR EXAMPLE:**

- 1) 0 – 20mA or a 4 – 20mA current inputs, would require a current to volt conversion, this can be achieved with a single resistor

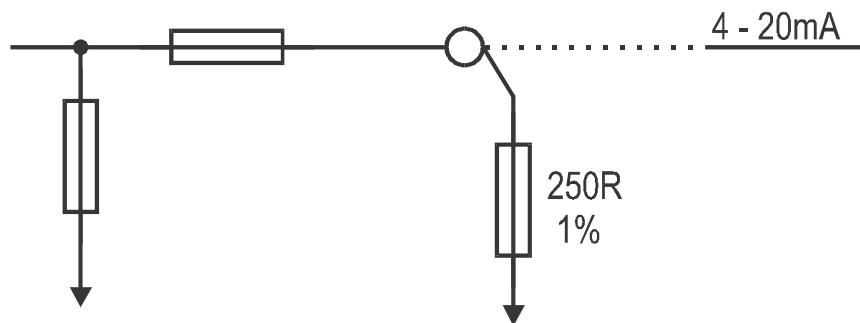

- 2) Any other non-compatible analog signal would have to be converted to the correct format.

Digital input signals have less constraints other than it must source with a voltage level not lower than 5V with a drive capacity of 1mA.

If a digital input from a field sensor does not drive or source but sink via an open collector transistor topology then a pull up resistor would be required.

**EXAMPLE:**

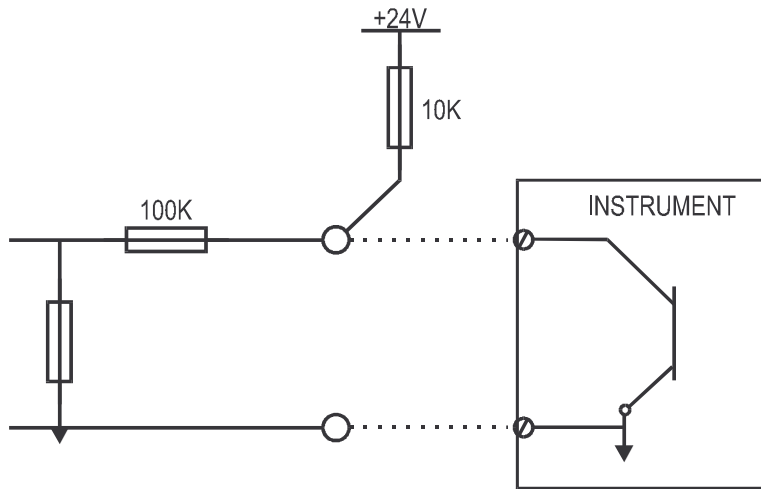

Another common type of input is the dry contact from a relay. With this type of input it can be wired to sink or source in either case the connection must be noted.

**Source Action:**

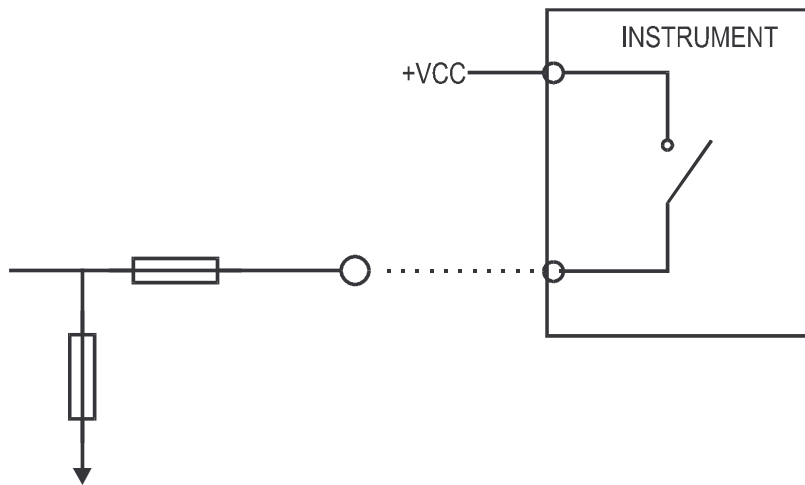

**Sink Action:**

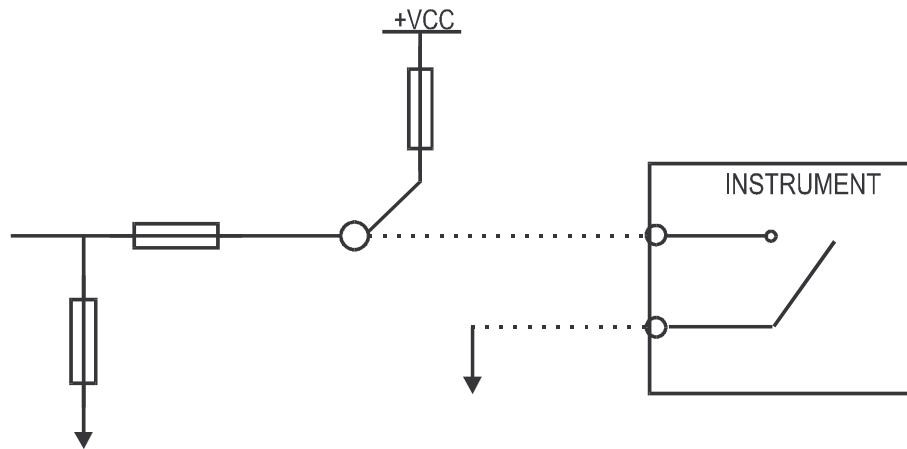

In this case it is required to add in a pull up resistor for the circuitry to operate correctly.

*(Care should always be taken not to violate any of the input parameters.)*

**NOTE:**

To simplify the above problems with different field equipment CSD have available as an optional element a resistor termination board that plugs in at the Micro RDAC base to help with some of the strapping.

# URDAc BASE MODULE

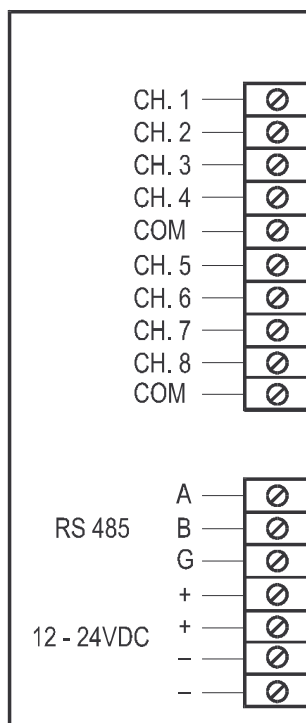

# MICRO RDAC PROGRAMMING CABLE

## 9 PIN D-TYPE MALE

RJ45

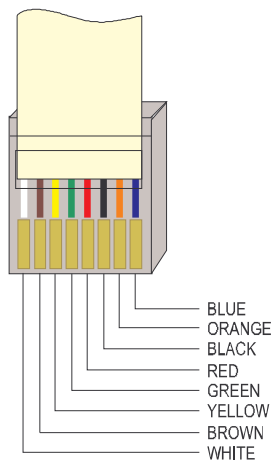

BOTTOM VIEW

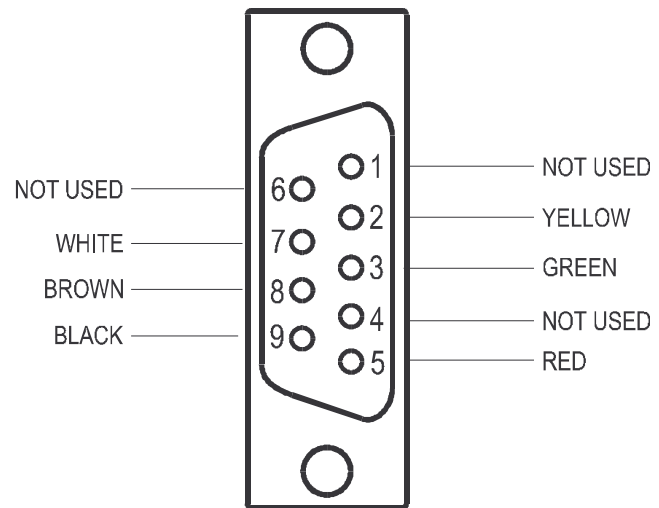

## Micro RDAc I/O

### Memory map:

The first 30 registers from 40001 to 40030 are internal RAM registers and contain the I/O map for the device as the following table indicates.

ADDRESS	FUNCTION	RANGE	MODE
40001	Digital outputs	0-255	W
40002	Analogue out 1 (CH15)	0-4095	W
40003	Analogue out 2 (CH16)	0-4095	W
40004	Write Command	0-65535	W
40005	Write Info 1	0-65535	W
40006	Write Info 2	0-65535	W
40007	Write Info 3	0-65535	W
40008	Write Info 4	0-65535	W
40009	Digital Inputs	0-255	R
40010	Counter 1 (CH 01)	0-65535	R
40011	Counter 2 (CH 02)	0-65535	R
40012	Counter 3 (CH 03)	0-65535	R
40013	Counter 4 (CH 04)	0-65535	R
40014	Counter 5 (CH 05)	0-65535	R
40015	Counter 6 (CH 06)	0-65535	R
40016	Counter 7 (CH 07)	0-65535	R
40017	Counter 8 (CH 08)	0-65535	R
40018	Analogue 1 (CH 09)		R
40019	Analogue 2 (CH 10)		R
40020	Analogue 3 (CH 11)		R
40021	Analogue 4 (CH 12)		R
40022	Analogue 5 (CH 13)		R
40023	Analogue 6 (CH 14)		R
40024	Analogue 7 (CH 15)		R
40025	Analogue 8 (CH 16)		R
40026	Read Command	0-65535	R
40027	Read Info 1	0-65535	R
40028	Read Info 2	0-65535	R
40029	Read Info 3	0-65535	R
40030	Read Info 4	0-65535	R

There is then a gap to make up 128 registers, and then from register 40129 the EEPROM is mapped for 180 registers.

## Micro RDAC I/O

### Configuration:

**NOTE!** The internal EEPROM is read and written directly using these registers so it is advisable not to use the registers as storage for continually updated parameters.

ADDRESS	FUNCTION	RANGE	MODE
40129	RDAC signature	0x1BAD	R
40130	Hardware Type	0-65535	R
40131	Software version	0-65535	R
40132	Reserved	0-65535	R
40133	Reserved	0-65535	R
40134	Reserved	0-65535	R
40135	Reserved	0-65535	R
40136	Reserved	0-65535	R
40137	Signature	0xABCD	R/W
40138	Port mode	1-RS232, 0-RS485	R/W
40139	Device address	1-254	R/W
40140	Baud-rate	300-19200	R/W
40141	Response Time	0-100ms	R/W
40142	Reserved	0-65535	R/W
40143	Reserved	0-65535	R/W
40144	Configuration	0-65535	R/W
40145	Reserved	0-65535	R/W
40146	Reserved	0-65535	R/W
40147	Reserved	0-65535	R/W
40148	Reserved	0-65535	R/W
40149	Reserved	0-65535	R/W
40150	Reserved	0-65535	R/W
40151	Reserved	0-65535	R/W
40152	Reserved	0-65535	R/W
40153	Reserved	0-65535	R/W
40154	Reserved	0-65535	R/W
40155	Reserved	0-65535	R/W
40156	Reserved	0-65535	R/W
40157	Reserved	0-65535	R/W
40158	Reserved	0-65535	R/W
40159	Reserved	0-65535	R/W
40160	Reserved	0-65535	R/W
40161	Reserved	0-65535	R/W
40162	Reserved	0-65535	R/W
40163	Reserved	0-65535	R/W
40164	Reserved	0-65535	R/W
40165	Reserved	0-65535	R/W
40166	Reserved	0-65535	R/W
40167	Reserved	0-65535	R/W
40168	Reserved	0-65535	R/W
40169	Reserved	0-65535	R/W
40170	Reserved	0-65535	R/W
40171	Reserved	0-65535	R/W
40172	Reserved	0-65535	R/W
40173	Reserved	0-65535	R/W
40174	Reserved	0-65535	R/W
40175	Reserved	0-65535	R/W

## Micro RDAc I/O

### Pushbutton configuration:

There are three push buttons on the base circuit board, that are used to program the device:

- MODE**           - Select the mode to program
- SELECT**       - Increment the program value
- RESET**         - Re-start the I/O processor after programming

#### Mode 1 - Port mode RS232 or RS485

LED 8	LED 7	LED 6	LED 5	LED 4	LED 3	LED 2	LED 1
Off	Off	On	x	x	x	x	Port mode

Port Mode:

Off = RS485 is selected as communications port

On = RS232 is selected as communications port

#### Mode 2- Device address

LED 8	LED 7	LED 6	LED 5	LED 4	LED 3	LED 2	LED 1
Off	On	Off	A4	A3	A2	A1	A0

Device address:

	A4	A3	A2	A1	A0		A4	A3	A2	A1	A0
1	Off	Off	Off	Off	On	17	On	Off	Off	Off	On
2	Off	Off	Off	On	Off	18	On	Off	Off	On	Off
3	Off	Off	Off	On	On	19	On	Off	Off	On	On
4	Off	Off	On	Off	Off	20	On	Off	On	Off	Off
5	Off	Off	On	Off	On	21	On	Off	On	Off	On
6	Off	Off	On	On	Off	22	On	Off	On	On	Off
7	Off	Off	On	On	On	23	On	Off	On	On	On
8	Off	On	Off	Off	Off	24	On	On	Off	Off	Off
9	Off	On	Off	Off	On	25	On	On	Off	Off	On
10	Off	On	Off	On	Off	26	On	On	Off	On	Off
11	Off	On	Off	On	On	27	On	On	Off	On	On
12	Off	On	On	Off	Off	28	On	On	On	Off	Off
13	Off	On	On	Off	On	29	On	On	On	Off	On
14	Off	On	On	On	Off	30	On	On	On	On	Off
15	Off	On	On	On	On	31	On	On	On	On	On
16	On	Off	Off	Off	Off	32	Off	Off	Off	Off	Off

## Micro RDAc I/O

### Pushbutton configuration:

#### Mode 3- Baudrate

LED 8	LED 7	LED 6	LED 5	LED 4	LED 3	LED 2	LED 1
Off	On	Off	X	x	B2	B1	B0

Baudrate	B2	B1	B0
<b>300</b>	Off	Off	Off
<b>600</b>	Off	Off	On
<b>1200</b>	Off	On	Off
<b>2400</b>	Off	On	On
<b>4800</b>	On	Off	Off
<b>9600</b>	On	Off	On
<b>19200</b>	On	On	Off
<b>38400</b>	On	On	On

#### Mode 4 – Response timeout

LED 8	LED 7	LED 6	LED 5	LED 4	LED 3	LED 2	LED 1
Off	On	Off	R4	R3	R2	R1	R0

#### Response Timeout:

ms	A4	A3	A2	A1	A0	ms	A4	A3	A2	A1	A0
0	Off	Off	Off	Off	Off	80	On	Off	Off	Off	Off
5	Off	Off	Off	Off	On	85	On	Off	Off	Off	On
10	Off	Off	Off	On	Off	90	On	Off	Off	On	Off
15	Off	Off	Off	On	On	95	On	Off	Off	On	On
20	Off	Off	On	Off	Off	100	On	Off	On	Off	Off
25	Off	Off	On	Off	On	105	On	Off	On	Off	On
30	Off	Off	On	On	Off	110	On	Off	On	On	Off
35	Off	Off	On	On	On	115	On	Off	On	On	On
40	Off	On	Off	Off	Off	120	On	On	Off	Off	Off
45	Off	On	Off	Off	On	125	On	On	Off	Off	On
50	Off	On	Off	On	Off	130	On	On	Off	On	Off
55	Off	On	Off	On	On	135	On	On	Off	On	On
60	Off	On	On	Off	Off	140	On	On	On	Off	Off
65	Off	On	On	Off	On	145	On	On	On	Off	On
70	Off	On	On	On	Off	150	On	On	On	On	Off
75	Off	On	On	On	On	155	On	On	On	On	On

# μRDAc BASE BOARD

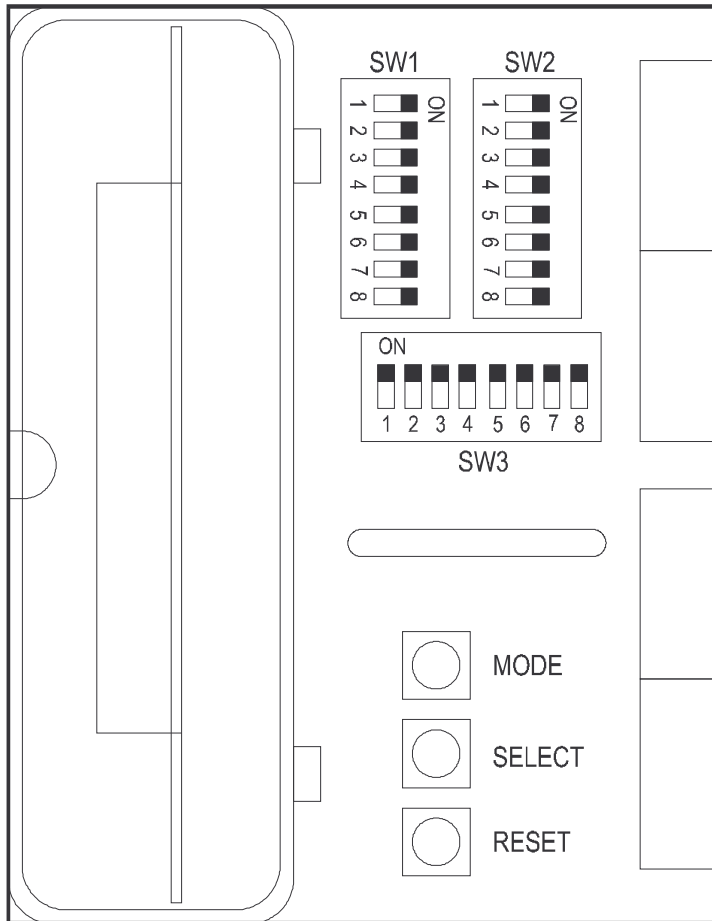

SW1 - Select an Output.

SW2 - Select a 250R Resistor for 4-20mA Input.

SW3 - Select 10K pull-up for open collector Input.

# μRDAC I/O



Cybernetic Software  
Development cc.

CK 92/2057/23

RDACIOFP.CDR